



POWERUP

# POWERUP TEACHER'S GUIDE

## LESSON PLANS FOR POWERED PAPER AIRPLANES



# TABLE OF CONTENT BELOW

---

## I. Introduction, PowerUp and STEM

## II. Learning Standards –

1.Primary, Middle, High School

2. PowerUp Learning Standards Alignment: How to Fly a Paper Airplane with a PowerUp Motor Getting Started Guide by Chapter

## III. Getting Started Guide –

How to Fly a Paper Airplane with a PowerUp Motor

# I. INTRODUCTION, POWERUP AND STEM

---

Creating and flying a paper airplane seems pretty straightforward. Making a paper airplane, observing it in flight and improving its design through experimentation is challenging and fun. Yet, this simple concept of flying paper airplanes is one of the main cornerstones of the broad field of aeronautics, and foundational to STEM learning.

Our fascination with aeronautics had led humans to the moon, the space station, and even to the exploration of Mars. We have satellites orbiting our planet which gather and relay massive amounts of information back to Earth. Spacecraft have been sent to planets throughout our solar system to explore atmospheres and surfaces.

Did you know the study of flight goes back to the 6th century or even earlier? The first successful powered flight is recorded by the Wright Brothers in the early 1900's but Leonardo da Vinci illustrated over 100 drawings explaining the theory of flight in the 1400's. Da Vinci's early studies resulted in the development of the modern-day helicopter.

From wind dependent kites, glider planes and hang gliders to propulsion driven airplanes and rockets, to unmanned aerial vehicles, otherwise known as drones, the field of aeronautics is a fascinating and evolving field for all ages. The fundamentals of aeronautics readily lend themselves to STEM activities for students across grade levels. The mechanics and flight of a simple paper airplane can be incorporated into many STEM lessons. Add a power source to a paper airplane and the connection to and integration of STEM goals is achieved.

STEM standards are at the core of Math, Science

and Literacy learning objectives. Long before these were introduced into our educational system Albert Einstein wrote,

*"To raise a new question, new possibilities, to regard old problems from a new angle, requires creative imagination and marks real advance in science."*

PowerUp's paper airplane kits allow students to do precisely what Einstein spoke of, imagine, create and explore.

With STEM careers expanding exponentially, the study of aeronautics can lead to high paying jobs. PowerUp learning tools introduce students to various aspects of aviation. This exploration could lead to further studies from avionics to aerospace engineering. Thousands of students could find careers in STEM areas according to a 2012 White House press release;

*"The United States will need approximately 1 million more STEM professionals than are projected to graduate over the next decade."*

PowerUp allows students to expand their sense of play and experimentation by adding power, adding mobile controls, and adding video streaming to the familiar paper airplane. Beginning with the principle of free gliding flight and then introducing the concept of thrust by the addition of a power motor to the paper airplane, PowerUp connects lessons and projects to STEM standards in a straightforward manner. Combine this with student imagination and natural curiosity, PowerUp airplanes help students master STEM standards, with fun and high engagement.

# II. POWERUP LEARNING STANDARDS

## (1) PRIMARY, MIDDLE, HIGH SCHOOL

---

The projects and lessons connected with the PowerUp learning tools align with nationally recognized learning standards. These standards have been determined and agreed upon for US educators and in the case of NGSS and ISTE, global educators.

The aligned standards include:

**NGSS** Next Generation Science Standards

**CCSS** Common Core State Standards

**ISTE** International Society for Technology in Education Standards

**CSTA** Computer Science Teacher Association Standards

---

### PRIMARY LEARNING STANDARDS

#### NGSS

##### **5-PS2 Motion and Stability: Forces and Interactions**

5-PS2-1. Support an argument that the gravitational force exerted by Earth on objects is directed down.

##### **3-5-ETS1 Engineering Design**

3-5-ETS1-1. Define a simple design problem reflecting a need or a want that includes specified criteria for success and constraints on materials, time, or cost.

3-5-ETS1-2. Generate and compare multiple possible solutions to a problem based on how well each is likely to meet the criteria and constraints of the problem.

3-5-ETS1-3. Plan and carry out fair tests in which variables are controlled and failure points are considered to identify aspects of a model or prototype that can be improved.

#### CCSS

RI.5.1 Quote accurately from a text when explaining what the text says explicitly and when drawing

inferences from the text.

RI.5.9 Integrate information from several texts on the same topic in order to write or speak about the subject knowledgeably.

MP.2 Reason abstractly and quantitatively

MP.4 Model with mathematics.

MP.5 Use appropriate tools strategically.

### MIDDLE SCHOOL LEARNING STANDARDS

#### NGSS

##### **MS-PS2 Motion and Stability: Forces and Interactions**

MS-PS2-2 Plan an investigation to provide evidence that the change in an object's motion depends on the sum of the forces on the object and the mass of the object.

##### **MS-PS3 Energy**

MS-PS3-1. Construct and interpret graphical displays of data to describe the relationships of kinetic energy to the mass of an object and to the speed of an object.

MS-PS3-5. Construct, use, and present arguments

to support the claim that when the kinetic energy of an object changes, energy is transferred to or from the object.

### **MS-ETS1 Engineering Design**

MS-ETS1-1. Define the criteria and constraints of a design problem with sufficient precision to ensure a successful solution, taking into account relevant scientific principles and potential impacts on people and the natural environment that may limit possible solutions.

MS-ETS1-2. Evaluate competing design solutions using a systematic process to determine how well they meet the criteria and constraints of the problem.

MS-ETS1-3. Analyze data from tests to determine similarities and differences among several design solutions to identify the best characteristics of each that can be combined into a new solution to better meet the criteria for success.

MS-ETS1-4. Develop a model to generate data for iterative testing and modification of a proposed object, tool, or process such that an optimal design can be achieved.

### **CCSS**

RST.6-8.1 Cite specific textual evidence to support analysis of science and technical texts, attending to the precise details of explanations or descriptions.

RST.6-8.3 Follow precisely a multistep procedure when carrying out experiments, taking measurements, or performing technical tasks.

RST.6-8.7 Integrate quantitative or technical information expressed in words in a text with a version of that information expressed visually (e.g., in a flowchart, diagram, model, graph, or table)

RST.6-8.9 Compare and contrast the information gained from experiments, simulations, video, or multimedia sources with that gained from reading a text on the same topic.

WHST.6-8.7 Conduct short research projects to answer a question (including a self-generated question), drawing on several sources and

generating additional related, focused questions that allow for multiple avenues of exploration.

WHST.6-8.9 Draw evidence from informational texts to support analysis, reflection, and research.

MP.2 Reason abstractly and quantitatively

6.SP.B.5 Summarize numerical data sets in relation to their context.

SL.8.5 Integrate multimedia and visual displays into presentations to clarify information, strengthen claims and evidence, and add interest.

## **HIGH SCHOOL LEARNING STANDARDS**

### **NGSS**

#### **HS-PS2 Motion and Stability: Forces and Interactions**

HS-PS2-1 Analyze data to support the claim that Newton's second law of motion describes the mathematical relationship among the net force on a macroscopic object, its mass, and its acceleration.

### **HS-ETS1 Engineering Design**

HS-ETS1-2. Design a solution to a complex real-world problem by breaking it down into smaller, more manageable problems that can be solved through engineering.

### **CCSS**

WHST.9-12.2 Write informative/explanatory texts, including the narration of historical events, scientific procedures/ experiments, or technical processes.

WHST.9-12.7 Conduct short as well as more sustained research projects to answer a question (including a self-generated question) or solve a problem; narrow or broaden the inquiry when appropriate; synthesize multiple sources on the subject, demonstrating understanding of the subject under investigation.

MP.2 Reason abstractly and quantitatively.

MP.4 Model with mathematics.

## K-12 ISTE STANDARDS

**1. EMPOWERED LEARNER** Students leverage technology to take an active role in choosing, achieving and demonstrating competency in their learning goals, informed by the learning sciences.

- 1a Students articulate and set personal learning goals, develop strategies leveraging technology to achieve them and reflect on the learning process itself to improve learning outcomes.
- 2b Students build networks and customize their learning environments in ways that support the learning environment.

**4. INNOVATIVE DESIGNER** Students use a variety of technologies within a design process to identify and solve problems by creating new, useful or imaginative solutions.

- 4a. Students know and use a deliberate design process for generating ideas, testing theories, creating innovative artifacts or solving authentic problems.
- 4c Students develop, test and refine prototypes as part of a cyclic design process.
- 4d. Students exhibit a tolerance for ambiguity, perseverance and the capacity to work with open-ended problems.

**5. COMPUTATIONAL THINKER** Students develop and employ strategies for understand and solving problems in ways that leverage the power of technological methods to develop and test solutions.

- 5c Students break problems down into component parts, extract key information, and develop models to understand complex systems or facilitate problem-solving.

**6. CREATIVE COMMUNICATOR** Students communicate clearly and express themselves creatively for a variety of purposes using the platforms, tools, styles, formats and digital media appropriate for their goals.

- 6a Students choose the appropriate platforms and tools for meeting the desired objectives of their creation or communication.
- 6d Students publish or present content that customizes the message and medium for their intended audiences.

**7. GLOBAL COLLABORATOR** Students use digital tools to broaden their perspectives and enrich their learning by collaborating with others and working effectively in teams locally and globally.

- 7c Students contribute constructively to project teams, assuming various roles and responsibilities to work effectively toward a common goal.

**\*NOTE** - ISTE Standards above apply to the PowerUp 2.0 plane. Additional ISTE standards may apply for PowerUp Dart, PowerUp FPV and PowerUp 3.0 planes. <https://www.iste.org/standards/for-students>

## K-12 CSTA STANDARDS

**\*NOTE** - CSTA Standards applicable to the PowerUp Dart, PowerUp FPV and PowerUp 3.0 planes can be found on the CSTA website: <https://www.csteachers.org/page/standards>

# II. POWERUP LEARNING STANDARDS ALIGNMENT

## (2) HOW TO FLY A PAPER AIRPLANE WITH A POWERUP MOTOR GETTING STARTED GUIDE BY CHAPTER

---

### CHAPTER 1

See general program standards across lessons and projects.

### CHAPTER 2

#### NGSS

3-5-ETS1-1 Define a simple design problem reflecting a need or a want that includes specified criteria for success and constraints on materials, time, or cost.  
MS-ETS1-1 Define the criteria and constraints of a design problem with sufficient precision to ensure a successful solution, taking into account relevant scientific principles and potential impacts on people and the natural environment that may limit possible solutions.

#### CCSS

MP.2 Reason abstractly and quantitatively.  
RST.6-8.3 Follow precisely a multistep procedure when carrying out experiments, taking measurements, or performing technical tasks.

#### ISTE

4. Innovative Designer Students use a variety of technologies within a design process to identify and solve problems by creating new, useful or imaginative solutions.  
4c Students develop, test and refine prototypes as part of a cyclic design process.  
5. Computational Thinker Students develop and employ strategies for understand and solving problems in ways that leverage the power of technological methods to develop and test solutions.  
5c Students break problems down into component parts, extract key information, and develop models

to understand complex systems or facilitate problem-solving.

7. Global Collaborator Students use digital tools to broaden their perspectives and enrich their learning by collaborating with others and working effectively in teams locally and globally.

7c Students contribute constructively to project teams, assuming various roles and responsibilities to work effectively toward a common goal.

### CHAPTER 3

#### NGSS

5-PS2-1 Support an argument that the gravitational force exerted by Earth on objects is directed down.  
MS-PS2-2 Plan an investigation to provide evidence that the change in an object's motion depends on the sum of the forces on the object and the mass of the object.  
MS-PS3-1 Construct and interpret graphical displays of data to describe the relationships of kinetic energy to the mass of an object and to the speed of an object.  
MS-PS3-5 Construct, use, and present arguments to support the claim that when the kinetic energy of an object changes, energy is transferred to or from the object.  
HS-PS2-1 Analyze data to support the claim that Newton's second law of motion describes the mathematical relationship among the net force on a macroscopic object, its mass, and its acceleration.

#### CCSS

RST.6-8.7 Integrate quantitative or technical information expressed in words in a text with a version of that information expressed visually (e.g., in a flowchart, diagram, model, graph, or table).

MP.2 Reason abstractly and quantitatively.

### **ISTE**

1. Empowered Learner Students leverage technology to take an active role in choosing achieving and demonstrating competency in their learning goals, informed by the learning sciences.

1a Students articulate and set personal goals, develop strategies leveraging technology to achieve them and reflect on the learning process itself to improve learning outcomes.

2b Students build networks and customize their learning environments in ways that support the learning environment.

7. Global Collaborator Students use digital tools to broaden their perspectives and enrich their learning by collaborating with others and working effectively in teams locally and globally.

7c Students contribute constructively to project teams, assuming various roles and responsibilities to work effectively toward a common goal.

## **CHAPTER 4**

### **NGSS**

5-PS2-1 Support an argument that the gravitational force exerted by Earth on objects is directed down.

3-5-ETS1-2 Generate and compare multiple possible solutions to a problem based on how well each is likely to meet the criteria and constraints of the problem.

3-5-ETS1-3 Plan and carry out fair tests in which variables are controlled and failure points are considered to identify aspects of a model or prototype that can be improved.

MS-PS2-2 Plan an investigation to provide evidence that the change in an object's motion depends on the sum of the forces on the object and the mass of the object.

MS-PS3-1. Construct and interpret graphical displays of data to describe the relationships of kinetic energy to the mass of an object and to the speed of an object.

MS-PS3-5 Construct, use, and present arguments to support the claim that when the kinetic energy of an object changes, energy is transferred to or from the object.

MS-ETS1-2 Evaluate competing design solutions using a systematic process to determine how well they meet the criteria and constraints of the problem.

HS-PS2-1 Analyze data to support the claim that Newton's second law of motion describes the mathematical relationship among the net force on a macroscopic object, its mass, and its acceleration.

### **CCSS**

RI.5.1 Quote accurately from a text when explaining what the text says explicitly and when drawing inferences from the text.

WHST.6-8.7 Conduct short research projects to answer a question (including a self-generated question), drawing on several sources and generating additional related, focused questions that allow for multiple avenues of exploration.

WHST.6-8.9 Draw evidence from informational texts to support analysis, reflection, and research.

MP.4 Model with mathematics.

MP.5 Use appropriate tools strategically.

### **ISTE**

4. Innovative Designer Students use a variety of technologies within a design process to identify and solve problems by creating new, useful or imaginative solutions.

4a Students know and use a deliberate design process for generating ideas, testing theories, creating innovative artifacts or solving authentic problems.

4d Students exhibit a tolerance for ambiguity, perseverance and the capacity to work with open-ended problems.

5. Computational Thinker Students develop and employ strategies for understand and solving problems in ways that leverage the power of technological methods to develop and test solutions.

5c Students break problems down into component parts, extract key information, and develop models



to understand complex systems or facilitate problem-solving.

7. Global Collaborator Students use digital tools to broaden their perspectives and enrich their learning by collaborating with others and working effectively in teams locally and globally.

7c Students contribute constructively to project teams, assuming various roles and responsibilities to work effectively toward a common goal.

## CHAPTER 5

### NGSS

5-PS2-1 Support an argument that the gravitational force exerted by Earth on objects is directed down.

3-5-ETS1-1 Define a simple design problem reflecting a need or a want that includes specified criteria for success and constraints on materials, time, or cost.

3-5-ETS1-2 Generate and compare multiple possible solutions to a problem based on how well each is likely to meet the criteria and constraints of the problem.

3-5-ETS1-3 Plan and carry out fair tests in which variables are controlled and failure points are considered to identify aspects of a model or prototype that can be improved.

MS-PS2-2 Plan an investigation to provide evidence that the change in an object's motion depends on the sum of the forces on the object and the mass of the object.

MS-PS3-1 Construct and interpret graphical displays of data to describe the relationships of kinetic energy to the mass of an object and to the speed of an object.

MS-PS3-5 Construct, use, and present arguments to support the claim that when the kinetic energy of an object changes, energy is transferred to or from the object.

MS-ETS1-1 Define the criteria and constraints of a design problem with sufficient precision to ensure a successful solution, taking into account relevant scientific principles and potential impacts on people

and the natural environment that may limit possible solutions.

HS-PS2-1 Analyze data to support the claim that Newton's second law of motion describes the mathematical relationship among the net force on a macroscopic object, its mass, and its acceleration.

HS-ETS1-2 Design a solution to a complex real-world problem by breaking it down into smaller, more manageable problems that can be solved through engineering.

### CCSS

RI.5.1 Quote accurately from a text when explaining what the text says explicitly and when drawing inferences from the text.

MP.2 Reason abstractly and quantitatively.

RST.6-8.1 Cite specific textual evidence to support analysis of science and technical texts, attending to the precise details of explanations or descriptions.

RST.6-8.3 Follow precisely a multistep procedure when carrying out experiments, taking measurements, or performing technical tasks.

RST.6-8.7 Integrate quantitative or technical information expressed in words in a text with a version of that information expressed visually (e.g., in a flowchart, diagram, model, graph, or table).

RST.6-8.9 Compare and contrast the information gained from experiments, simulations, video, or multimedia sources with that gained from reading a text on the same topic.

WHST.6-8.9 Draw evidence from informational texts to support analysis, reflection, and research.

MP.2 Reason abstractly and quantitatively.

6.SP.B.5 Summarize numerical data sets in relation to their context.

### ISTE

4. Innovative Designer Students use a variety of technologies within a design process to identify and solve problems by creating new, useful or imaginative solutions.

4a. Students know and use a deliberate design

process for generating ideas, testing theories, creating innovative artifacts or solving authentic problems.

4c Students develop, test and refine prototypes as part of a cyclic design process.

5 Computational Thinker Students develop and employ strategies for understand and solving problems in ways that leverage the power of technological methods to develop and test solutions.

5c Students break problems down into component parts, extract key information, and develop models to understand complex systems or facilitate problem-solving.

7. Global Collaborator Students use digital tools to broaden their perspectives and enrich their learning by collaborating with others and working effectively in teams locally and globally.

7c Students contribute constructively to project teams, assuming various roles and responsibilities to work effectively toward a common goal.

## CHAPTER 6

### NGSS

5-PS2-1 Support an argument that the gravitational force exerted by Earth on objects is directed down.

3-5-ETS1-1 Define a simple design problem reflecting a need or a want that includes specified criteria for success and constraints on materials, time, or cost.

3-5-ETS1-2 Generate and compare multiple possible solutions to a problem based on how well each is likely to meet the criteria and constraints of the problem.

3-5-ETS1-3 Plan and carry out fair tests in which variables are controlled and failure points are considered to identify aspects of a model or prototype that can be improved.

MS-PS3-1 Construct and interpret graphical displays of data to describe the relationships of kinetic energy to the mass of an object and to the speed of an object.

MS-PS3-5 Construct, use, and present arguments to support the claim that when the kinetic energy of an

object changes, energy is transferred to or from the object.

MS-ETS1-1 Define the criteria and constraints of a design problem with sufficient precision to ensure a successful solution, taking into account relevant scientific principles and potential impacts on people and the natural environment that may limit possible solutions.

MS-ETS1-2 Evaluate competing design solutions using a systematic process to determine how well they meet the criteria and constraints of the problem.

MS-ETS1-3 Analyze data from tests to determine similarities and differences among several design solutions to identify the best characteristics of each that can be combined into a new solution to better meet the criteria for success.

MS-ETS1-4 Develop a model to generate data for iterative testing and modification of a proposed object, tool, or process such that an optimal design can be achieved.

HS-PS2-1 Analyze data to support the claim that Newton's second law of motion describes the mathematical relationship among the net force on a macroscopic object, its mass, and its acceleration.

HS-ETS1-2 Design a solution to a complex real-world problem by breaking it down into smaller, more manageable problems that can be solved through engineering.

### CCSS

MP.5 Use appropriate tools strategically.

RST.6-8.3 Follow precisely a multistep procedure when carrying out experiments, taking measurements, or performing technical tasks.

RST.6-8.7 Integrate quantitative or technical information expressed in words in a text with a version of that information expressed visually (e.g., in a flowchart, diagram, model, graph, or table).

RST.6-8.9 Compare and contrast the information gained from experiments, simulations, video, or multimedia sources with that gained from reading a text on the same topic.

WHST.6-8.7 Conduct short research projects to

answer a question (including a self-generated question), drawing on several sources and generating additional related, focused questions that allow for multiple avenues of exploration.

MP.2 Reason abstractly and quantitatively.

6.SP.B.5 Summarize numerical data sets in relation to their context.

## **ISTE**

4. Innovative Designer Students use a variety of technologies within a design process to identify and solve problems by creating new, useful or imaginative solutions.

4a. Students know and use a deliberate design process for generating ideas, testing theories, creating innovative artifacts or solving authentic problems.

4c Students develop, test and refine prototypes as part of a cyclic design process. 4d Students exhibit a tolerance for ambiguity, perseverance and the capacity to work with open-ended questions.

5 Computational Thinker Students develop and employ strategies for understand and solving problems in ways that leverage the power of technological methods to develop and test solutions.

5c Students break problems down into component parts, extract key information, and develop models to understand complex systems or facilitate problem-solving.

7. Global Collaborator Students use digital tools to broaden their perspectives and enrich their learning by collaborating with others and working effectively in teams locally and globally.

7c Students contribute constructively to project teams, assuming various roles and responsibilities to work effectively toward a common goal.

## **CHAPTER 7**

### **NGSS**

3-5-ETS1-3 Plan and carry out fair tests in which variables are controlled and failure points are considered to identify aspects of a model or prototype that can be improved.

MS-ETS1-2 Evaluate competing design solutions using a systematic process to determine how well they meet the criteria and constraints of the problem.

MS-ETS1-3 Analyze data from tests to determine similarities and differences among several design solutions to identify the best characteristics of each that can be combined into a new solution to better meet the criteria for success.

MS-ETS1-4 Develop a model to generate data for iterative testing and modification of a proposed object, tool, or process such that an optimal design can be achieved.

HS-ETS1-2 Design a solution to a complex real-world problem by breaking it down into smaller, more manageable problems that can be solved through engineering.

### **CCSS**

RI.5.1 Quote accurately from a text when explaining what the text says explicitly and when drawing inferences from the text.

RI.5.9 Integrate information from several texts on the same topic in order to write or speak about the subject knowledgeably.

RST.6-8.3 Follow precisely a multistep procedure when carrying out experiments, taking measurements, or performing technical tasks.

RST.6-8.7 Integrate quantitative or technical information expressed in words in a text with a version of that information expressed visually (e.g., in a flowchart, diagram, model, graph, or table).

RST.6-8.9 Compare and contrast the information gained from experiments, simulations, video, or multimedia sources with that gained from reading a text on the same topic.

WHST.6-8.7 Conduct short research projects to answer a question (including a self-generated question), drawing on several sources and generating additional related, focused questions that allow for multiple avenues of exploration.

SL.8.5 Integrate multimedia and visual displays into presentations to clarify information, strengthen claims and evidence, and add interest.

WHST.9-12.2 Write informative/explanatory texts, including the narration of historical events, scientific procedures/ experiments, or technical processes.

WHST.9-12.7 Conduct short as well as more sustained research projects to answer a question (including a self-generated question) or solve a problem; narrow or broaden the inquiry when appropriate; synthesize multiple sources on the subject, demonstrating understanding of the subject under investigation.

## **ISTE**

4. Innovative Designer Students use a variety of technologies within a design process to identify and solve problems by creating new, useful or imaginative solutions.

4a. Students know and use a deliberate design process for generating ideas, testing theories, creating innovative artifacts or solving authentic problems.

4c Students develop, test and refine prototypes as part of a cyclic design process.

5. Computational Thinker Students develop and employ strategies for understand and solving problems in ways that leverage the power of technological methods to develop and test solutions.

5c Students break problems down into component parts, extract key information, and develop models to understand complex systems or facilitate problem-solving.

7. Global Collaborator Students use digital tools to broaden their perspectives and enrich their learning by collaborating with others and working effectively in teams locally and globally.

7c Students contribute constructively to project teams, assuming various roles and responsibilities to work effectively toward a common goal.

# 3. GETTING STARTED GUIDE – HOW TO FLY A PAPER AIRPLANE WITH A POWERUP MOTOR

---

The lesson will last for approximately 90 minutes and can be shortened, if necessary, to 60 minutes.

Lesson overview: This lesson is meant for a teacher who wishes to conduct a single classroom lesson. It does not teach aerodynamics; rather, it is targeted toward a simple goal – enabling students to fly a paper airplane for a length of time greater 15 seconds possibly breaking the current world record of paper airplane flight! Of course, to accomplish this goal, you will need a PowerUp Motor.

**Objectives:** The student will fly a paper airplane for more than 15 seconds using the PowerUp Motor. The student will recognize how to improve flight time by modifying the structure of the paper airplane accordingly. The lesson will last for approximately 90 minutes and can be shortened, if necessary, to 60 minutes.

## CHAPTER TITLES

1. Lesson Preparation
2. How to Fold the Perfect Paper Airplane
3. The principals of flying a paper airplane
4. How to Fly a Paper Airplane without a Motor
5. How to Fly a Paper Airplane with a PowerUp® Motor
6. Common mistakes and tips
- 7 Conclusion and Final Competition



# CHAPTER 1 LESSON PREPARATION

In order to conduct a successful lesson, you must follow these guidelines. Please read this document in its entirety before you conduct the lesson.

**LESSON LOCATION:** Paper airplanes are highly influenced by wind. Wind gusts above 5-7 knots will cause turbulence and will not provide a successful experience. If possible, book your school gymnasium for this lesson. Make sure that the space is open and free of obstacles. If you have no access to a gym, use an open basketball or tennis court. Avoid areas with trees, airplanes can easily get caught on them. Soft ground (e.g., grass or sand) provides a preferable landing surface. However, concrete and asphalt are acceptable when necessary.

**PRACTICE:** Never present a lesson before you have practiced folding the recommended airplane design and have managed to fly it successfully using the PowerUp motor. Prepare a sample airplane, adjust the model, and attach the motor. Fly the paper airplane at the location where you will conduct your lesson. If possible, conduct your practice lesson at the same time of day. This will provide you with beneficial information regarding the pros and cons of the site that you have chosen.

**NOTE:** If you experience strong wind on the day that you plan to conduct the lesson, we recommend that you postpone the lesson to a day with more moderate wind conditions.

## MATERIALS LIST:

- 1 PowerUp kit per student (fig 1)
- 1 PowerUp kit per teacher
- 1 Extra PowerUp kit for every 10 students
- 3 Alkaline batteries (size AA) per student, plus 10% surplus
- 1 Philips screwdriver
- 1-3 Scissors
- 1 Colored pencil for every 2 students
- PowerUp pilot stickers
- Permanent markers

## HANDOUTS:

- How To Fold instructions
- Pre-printed high quality (80-90 GSM / 20 lb) copier paper – Use only the recommended template (A4 or US letter 8.5 x 11 inches) (<http://www.poweruptoys.com/pages/download-electric-paper-airplane-templates>)
- Corrective cycle checklist



(fig 1)

# CHAPTER 2 HOW TO FOLD THE PERFECT PAPER AIRPLANE

This model (fig2) is based on the Nakamura Lock design and was modified to fly perfectly with the PowerUp motor.

## PERSONALIZE YOUR AIRPLANE

Handout pre-printed airplane templates to all students. Allow students to decorate the airplane in the predefined circles, those which are meant for the squadron symbol and the short dashed line for name tag. Cut the elevators and rudders along the bold line.

## FOLD THE PERFECT AIRPLANE

In the Appendix you will find folding instructions and a template that you can print and handout. Choose the preferred template according to the type of paper you have available - 8.5"X11" US letter or A4 . You can also download and print this template: <http://www.poweruptoys.com/pages/download-electric-paper-airplane-templates>

Printing tip: Choose the "Fit to Page" option.

## HANDOUT DIAGRAMS NOTES:

Diagram 1: It is important that students fold the paper in half accurately (fig 3). Make sure that all students fold slowly through this step in order to obtain two identical sides.

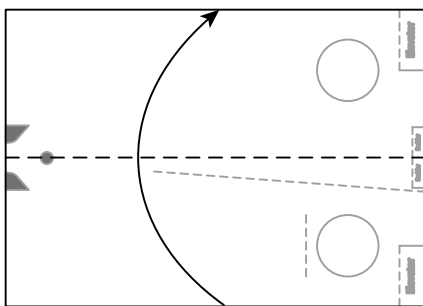

(fig 3)

Diagram 2-6 : When folding the arrow head, it is critical to align the edge of the paper with the central fold line. Make sure that students do not pass the center line. You can simplify this step by completing it while the paper is still folded in half.

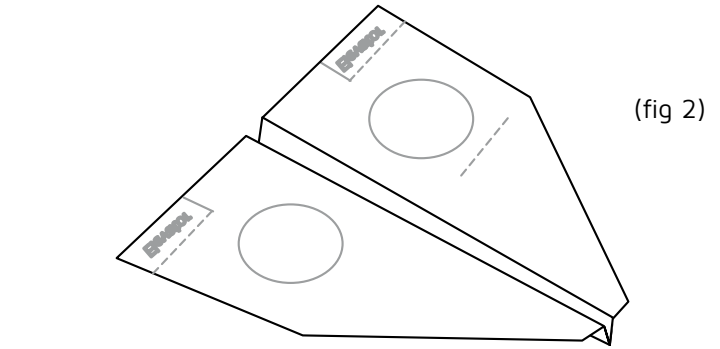

## GENERAL FOLDING TIPS:

- Use your fingernails to make hard creases.
- Make sure that flat surfaces stay flat during the folding process.
- Make all folds symmetrical. Note that the printed template may not be centered on the paper. Folding a symmetrical airplane is more important than adhering exactly to the printed lines on the template.

Diagram 7: Make sure that the corners are folded to the spot marked on the template this will provide a stable airplane design when using the powerUp System (fig 4).

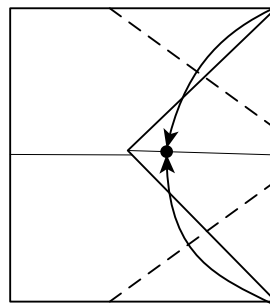

(fig 4)

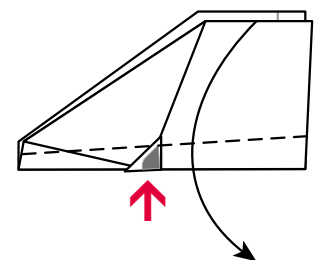

(fig 5)

Diagram 11: When folding the wings, students must make sure that the fold line of the wings passes through the thick triangle. This triangle will be the holding point of the airplane (fig 5).

# CHAPTER 3 THE PRINCIPALS OF FLYING A PAPER AIRPLANE

## THEORETICAL KNOWLEDGE

Flying a paper airplane successfully requires adjustments right before launch. The sections listed below will help you control your airplane.

**ANHEDRAL AND DIHEDRAL ANGLE:** The upward angle between the wings is a dihedral angle (fig 5). The dihedral angle eliminates an inverted or spiral flight. You can show the students what happens when you launch an airplane with an anhedral angle (fig 6). Note that because the paper is not stiff, the lift applied to the wing during flight will cause the paper to fold and increase the dihedral angle. To avoid this, always set your dihedral angle slightly lower than desired. An increased dihedral angle will cause a reduction in lift resulting with a lower flight time in total.

**ELEVATORS:** The elevators are the two flaps located on the rear portion of the wings (fig 7). Simply demonstrate to students that when the air hits the elevator, it creates a force that attempts to unfold the two flaps. For example, if the elevators are pointing up and the paper is strong enough, the momentum created will force the back of the airplane down, causing the nose to pitch up. Note that while this is not an official aerodynamic explanation, it can become a general rule of thumb for students to follow: Elevator Up = Tail Down = Nose Up. While it is possible to adjust the elevators in two opposite directions (e.g., to achieve a permanent roll), do not use this method to adjust an unwanted roll. An unwanted roll is probably caused by an asymmetric fold. It will be easier for you to fold a new airplane than to try to correct the roll using the elevators.

**RUDDER:** The rudder is the vertical flap at the rear end of the airplane (fig 7). The rudder is similar to an elevator that stands on its side. Move the rudder left to force the tail to the right and the nose of the airplane to the left. Rudder left = nose left.

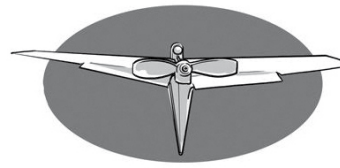

Dihedral (fig 5)

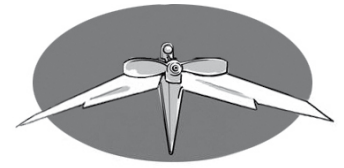

Anhedral (fig 6)

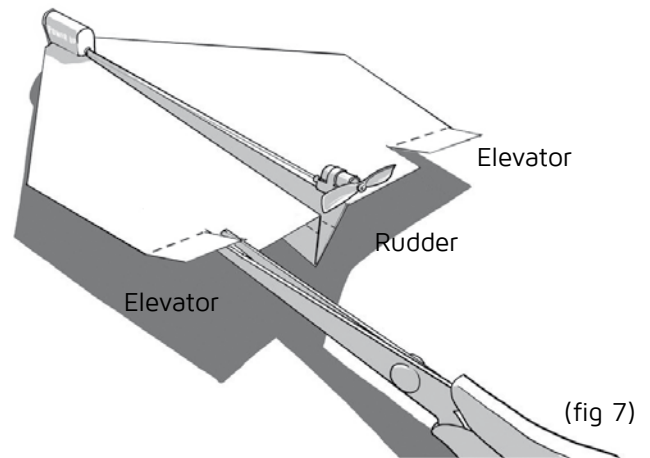

(fig 7)



**LAUNCHING:** Before starting this phase, gather all of your students together and brief them. Describe your objectives for this phase, explain the steps that you will go through, and remind them the principles of adjusting the airplane which you recently showed them. Remember that briefing and debriefing are major tools in improving your flying skills.



# CHAPTER 4 HOW TO FLY A PAPER AIRPLANE WITHOUT A MOTOR

**STEP 1: ADJUST** – Level all control surfaces. Make sure that you begin with zero influence from rudder and elevators, Set the dihedral according to the diagram, just a little above the horizon (fig 8).

**STEP 2: WIND CHECK** – Lift is generated when air flows on the wing. When you hold the airplane facing the wind, lift will be generated even before you launch it. This is why you must launch into the wind. In order to determine wind direction, you may wish to make your own wind sock. There are other ways to determine wind direction, such as watching sand drift from your fingers, wetting a finger and holding it up or observing smoke or flags to determine wind direction. If you are conducting the lesson in a closed space, select the longest available path for flight.

**STEP 3: HOW TO HOLD AIRPLANE** – You must hold your airplane very close to the center of gravity. With this model, you will grasp the airplane at the small multi-layered triangle, just a bit to the front from the center. Hold the airplane between the thumb and index finger of your strongest hand.

**STEP 4: LAUNCH** – Never throw an airplane. Launching a paper airplane is more like pushing a boat through the water. Keep your airplane level, your hand close to your face, 'push the boat' forward, and let go at the end of your hand movement.

## WHAT HAPPENED? THE CORRECTIVE CYCLE

In most cases you will not achieve a straight and level flight. One or more of the phenomena described below will occur. Observe carefully to determine which phenomena occur so that you can debrief the pilots at the end of each launch. During debriefing, make sure to ask students for their insights into correcting errors.

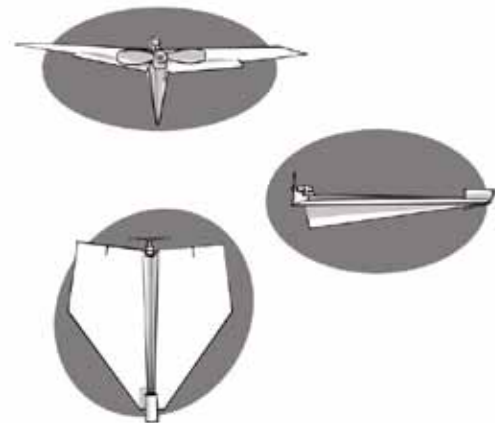

(fig 8)

**PHENOMENON 1: STALL** – When the nose of the airplane pitches up, beyond a certain point, the airflow may detach from the upper surface of the wing causing turbulence and dramatic reduction of lift followed by a nose down dive (fig 9).

Demonstrate this phenomenon to your students with a paper airplane in hand. To correct a stall, adjust the elevators slightly down. A stall is unlikely to occur unless the elevators were folded up by mistake. The basic behavior of the NAKAMURO airplane model is very stable. Such a mistake can occur if a student diverts significantly from a template or dramatically alters the distance between the center of lift and the center of gravity. If this occurs, suggest that the student folds another airplane.

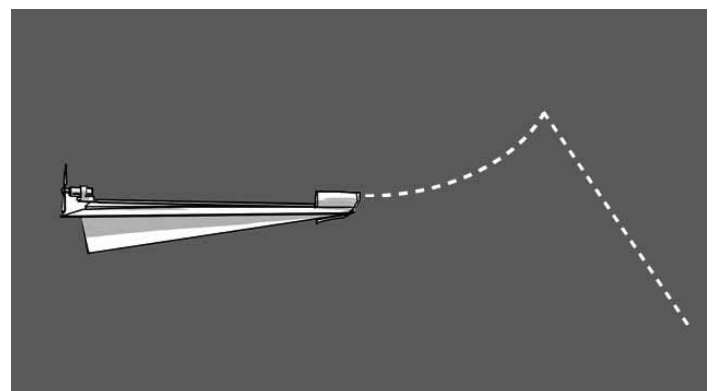

Stall (fig 9)

**PHENOMENON 2: DIVE** – A dive occurs when the airplane loses height quickly and the nose suddenly points toward the ground. (fig 10) To correct this phenomenon, evenly adjust the elevators upward.

**PHENOMENON 3: INVERTED FLIGHT** – This can occur when the airplane flips over and flies with its underbelly pointed up. An inverted flight indicates a problem with the angle between the right and left wings. Show the students the airplane from the front and ask them whether the wings are horizontal, pointing up (dihedral angle) or pointing down (anhedral angle). A dihedral angle provides the airplane with stability, as both vectors of lift are pointing slightly inward. An anhedral angle causes every slight change in the roll angle to increase until the airplane is inverted. In this new inverted position, the airplane has achieved a dihedral angle and is once again stable. To correct an inverted flight, make sure that your airplane wings form a dihedral angle.

**PHENOMENON 4: BANK** (left or right) – A bank is a steady turn. During a bank, the lift vector is no longer pointing up causing a slight decent. To correct an unintentional bank, use the rudder. The rudder is the V-shape located on the lower back part of the tail. The rudder tends to stay open, by slightly bending the rudder to the left or to the right you can correct your airplanes banking phenomenon (fig 11). Later on you will see the benefits of a steady bank – you can adjust your airplan to bank and return right back to your hand, or you can bank your airplane to stay in the air for a while in one area. For now, however, you want your students to achieve a straight and level flight.

**PHENOMENON 5: SPIRAL DIVE** – The combination of a dive and a bank causes a spiral dive. To correct a spiral dive, use the tools described above for both phenomena. You may also want to increase the dihedral in order to reduce the effect of the spiral dive.

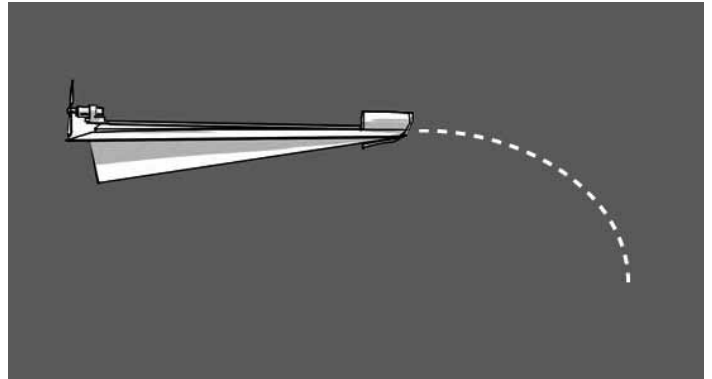

Dive (fig 10)

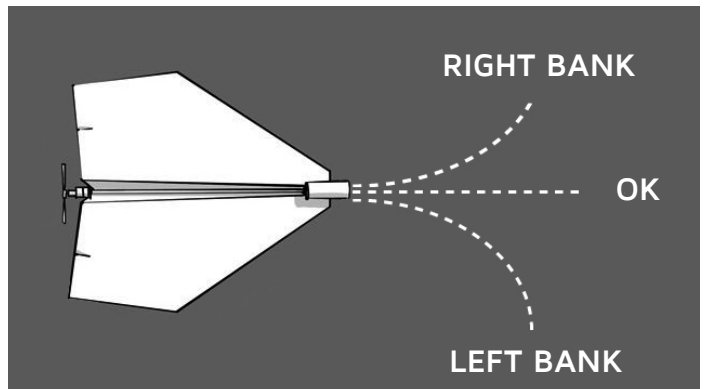

Banking (fig 11)

# CHAPTER 5 HOW TO FLY A PAPER AIRPLANE WITH POWERUP MOTOR

Up to this point, we have been flying paper airplane gliders. We will now add a motor to our paper airplanes. The principles that you learned earlier in the lesson will not change. How will a motor affect our airplane? A running motor provides constant thrust. If the airplane is trimmed correctly, the thrust provides a major component for a successful first flight. The motor will add some weight to the paper airplane, approximately an addition of 0.2 ounces or 6.5 grams. This extra weight means that your airplane will need more lift. The higher speed provided by the motor will create the necessary additional lift. In order to quickly attain this higher speed, you will launch the airplane a bit stronger. The rotation of the propeller will create yaw momentum. This is nothing to worry about, as it can be fixed with a little adjustment in the rudder. Brief your students about the changes that occur when we add a motor.

**Step 1: Install the Motor** – Handout PowerUp motor sets to the students. Show them how to attach the motor and the underside fin to the airplane with the clips (fig 1); refer to the instructional manual included in the kit). Make sure that the units have been installed properly.

**Step 2: Dry Launch** – Test-fly the aircraft without running the motor. Adjust airplane control surfaces until you obtain a steady descending flight (fig 13). Remind students about important launching features, including wind, adjustments, and launching force.

**Step 3: Ignition** – Hold the aircraft with your throwing hand. Use the other hand to plug the battery pack into the charging port tightening. Listen to the propeller wooshing sound as the main indicator for the increase of thrust. Count from 21 to

Stop here and ask for full attention now, as you are about to talk about SAFETY!

**SAFETY FIRST** – The PowerUp motor meets all 8+ (ASTM, EN71) safety standards, nevertheless make every effort to take the precautions listed below.

1. Individuals with long hair should pull hair back and fasten it with a rubber band. If hair becomes caught in the propeller, detach the propeller from the motor in order to release the hair.
2. Never allow the propeller to get close to the eyes.
3. In order to extend the lifespan of the motor, do not charge the motor for more than 20 seconds at a time.
4. After a full charge (20 seconds) allow the motor to cool down for two minutes.
5. Any time that you adjust or hold the airplane, stop the rotor by using the "Propeller Stop" feature on the charger.

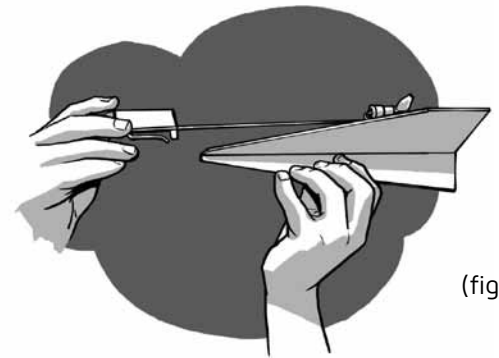

(fig 12)



(fig 13)

27 (7 seconds), the goal of the first flight is simply to observe the flight path. Do not hesitate after charging! Launch immediately.

**STEP 4: LAUNCH** – If the wind is strong (5mph), there is no need to apply force. During launch you can simply hold the nose heading into the wind and release the airplane gently, providing only a tiny push forward. Please make sure to pick up the airplane carefully so as to avoid any warping to the wings. It is best to hold the airplane either by the nose piece or by the body of the airplane.

**STEP 5: APPLYING THE CORRECTIVE CYCLE** – Upon failure, children as well as adults tend to repeat their last action with more force. Extra force will not help in this situation. Each student must identify and understand the phenomena that the airplane experienced. Students may continue on to the next step after describing what they learned.

This is the Corrective Cycle in use: observe, identify, correct, try again. Some students will experience stalls; some students will achieve wide banks. Encourage students to identify the phenomena and share how they corrected.

**NOTE:** recharge your motor before every launch!

**STEP 6: STALL** – It is considered good practice to begin by stalling your airplane. A stall is a definite situation, and it is easier to get into a stall than to find the right trim for straight and level flights. In order to stall your airplane, fold up the elevators. Do not over-fold the elevators, as this will cause air breaks. Allow students to try their settings. This process will allow students to adjust the rudder and create a stalled flight pointing straight.

**STEP 7: STRAIGHT AND LEVEL FLIGHT** – to correct the stall, gently lower the position of the elevators.

---

## CHAPTER 6 COMMON MISTAKES AND TIPS

**STEP 8: BANKING** – This step is made available for advanced students. Students that have maintained the straight and level flight can try now to attain a gentle bank by trimming the rudder. A successful flight will enable the airplane to return to the hands of the pilot.

### COMMON MISTAKES

1. Poor folding / asymmetric structure
2. Warping the paper during the folding process
3. Flying on a windy day
4. Excessive airplane adjustments
5. Applying too much force when launching
6. Not launching into the wind
7. Lifting the airplane by the wing, thus changing the wing structure
8. Trying again and again without applying a corrective action and understanding the reasons for a flight pattern

**NOTE:** that in that lesson it is not advised to charge the motor to its full 20 seconds. A 10 seconds charge will be sufficient for most flights.

### TIPS

1. First launches may not be successful. Encourage your students to learn from each launch, identify, adjust and try again.
2. Always use fresh batteries, never use rechargeable ones, since the voltage will be too low.
3. Landing on hard floors can cause the propeller to detach from the motor. If that happens, stop the motor with the charger and re-install the detached propeller when the concave side is pointing backwards.
4. When flying inside a gym, make sure the air conditioner doesn't cause turbulences. If so, ask to turn it off.
5. When all else fails, fold a new airplane.

# CHAPTER 7 CONCLUSION & FINAL COMPETITION

## FINAL COMPETITION

At the end of the day, all of the pilots will gather in the briefing room. This will be an important time when the flight cadets are learning and affixing their new knowledge. Debriefing starts by identifying positive points. Students will gain knowledge when they recognize the aspects of a successful flight. Try to focus only on the three major points that were observed, this will make it easier for the students to remember what they have learned from the process.

## CONCLUSION

If you still have time, you can arrange a competition. The activity addresses flight duration rather than flight distance.

1. Divide the students into groups of four.
2. Ask them to choose a squadron logo and decorate new templates.
3. Allow each squadron to use paper in different colors.
4. The competition is completed in sections. Choose a pilot from each squadron and set them in a row.
5. Set time for starting ignition by calling out, "get ready to ignite in 4, 3, 2, 1, Take off!
6. Do not measure time; rather, identify the landing order.
7. Give 7 points to the plane that flew the farthest, 5 points to the second place finisher, and 1 point to others.
8. Repeat this process with all pilots.
9. At the end of the project, reward all pilots with the Solo Pilot Sticker.
10. Present trophies to winners.

Need help? Call 7866001752

<http://www.poweruptoys.com>

© 2013 TailorToys L.L.C. This guide is subject to copyright. All rights are reserved.

PowerUp® is a trademark of TailorToys L.L.C



DESIGNED BY  
SHAI GOITEIN



POWERUP

### PowerUp Pilot Check List

## Flight without a motor

Check:

Align elevators -

Align rudder -

Make a slight dihedral -

Check wind direction -

### What happened?

Round Stall Dive Bank Flip over

1

Change Elevator Elevator Rudder Dihedral

↓ ↑ → ← ↘

2

Change Elevator Elevator Rudder Dihedral

↓ ↑ → ← ↘

3

Change Elevator Elevator Rudder Dihedral

↓ ↑ → ← ↘



POWERUP

### PowerUp Pilot Check List

## Flight with a motor

Check:

Align elevators -

Align rudder -

Make a slight dihedral -

Check wind direction -

### What happened?

Round Stall Dive Bank Flip over

1

Change Elevator Elevator Rudder Dihedral

↓ ↑ → ← ↘

2

Change Elevator Elevator Rudder Dihedral

↓ ↑ → ← ↘

3

Change Elevator Elevator Rudder Dihedral

↓ ↑ → ← ↘



POWERUP

### PowerUp Pilot Check List

## Flight with a motor

Check:

Align elevators -

Align rudder -

Make a slight dihedral -

Check wind direction -

### What happened?

Round Stall Dive Bank Flip over

1

Change Elevator Elevator Rudder Dihedral

↓ ↑ → ← ↘

2

Change Elevator Elevator Rudder Dihedral

↓ ↑ → ← ↘

3

Change Elevator Elevator Rudder Dihedral

↓ ↑ → ← ↘

# How to fold the best PowerUp paper airplane

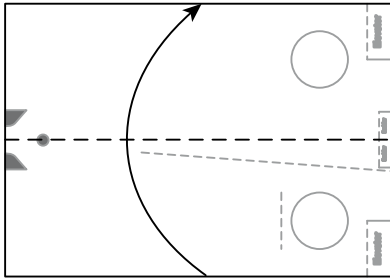

1. Start with the printed template face up. Fold in half, the lower edge to the top edge.

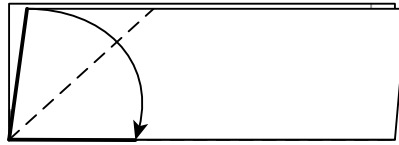

2. Make an Arrow Head by folding the left edge to the bottom edge (both are marked by thick lines).

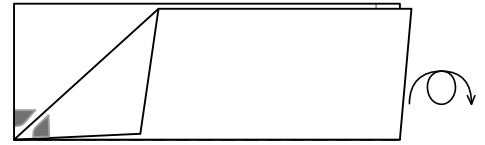

3. Turn over the model.

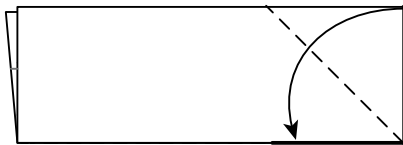

4. Repeat step 2. on this side.

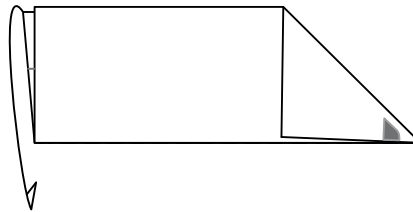

5. Spread the paper (unfold only the center line).

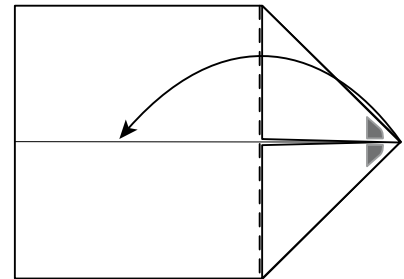

6. Fold the right corner to the left; refer to the base of the triangle as your guiding line.

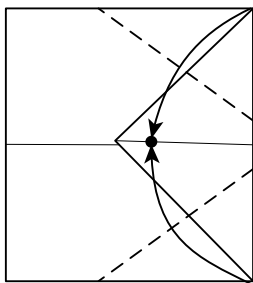

7. Bring both marked corners to the black dot.

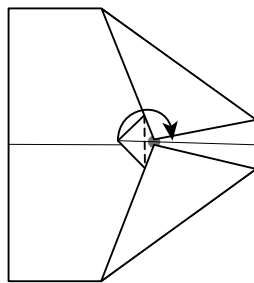

8. Lock the corners by folding the little triangle on top of the two corners.

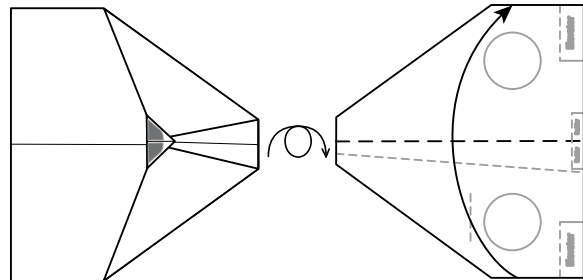

9. Lock the corners by folding the little triangle on top of the two corners.

10. Fold the model in half by aligning the wings. Note the dashed line in the lower wing.

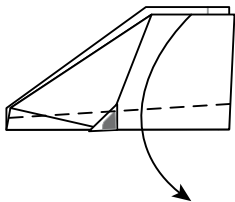

11. Fold the wing down along the mentioned dashed line.

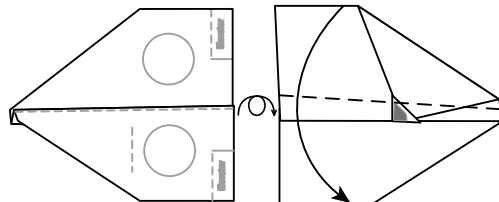

12. Turn the model over.

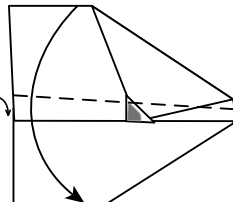

13. Fold the other wing and align it with the first wing.

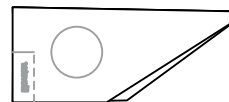

14. Spread the wings to the sides.

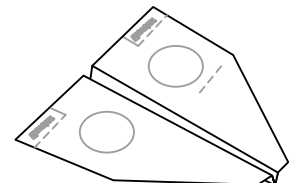

15. Your airplane is ready!

The best Template for the PowerUp 2.0  
Electric Paper Airplane Conversion Kit  
Paper Type - 20lb stock  
Paper size - US letter 8.5"X11"  
Printer Setting - Scale 100% borderless  
[www.poweruptoys.com](http://www.poweruptoys.com)



Copyright © 2013 TailorToys L.L.C. All rights reserved.  
PowerUp® is a trademark of TailorToys L.L.C.



[How to fold video](#)

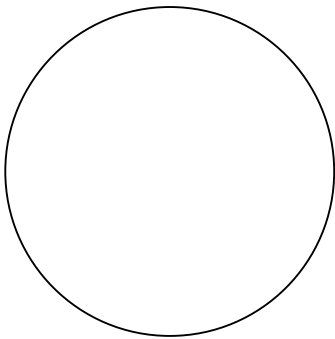
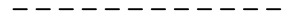

Elevator



Wing folding line

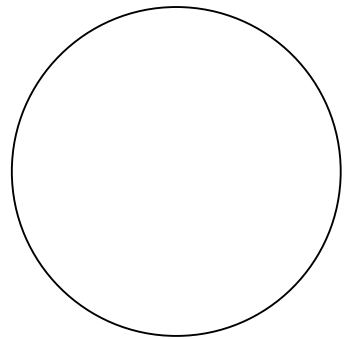

Elevator

Rudder

Rudder