

TEACHERS
Serving
TEACHERS!®

Mica Demo Kit

PF-8

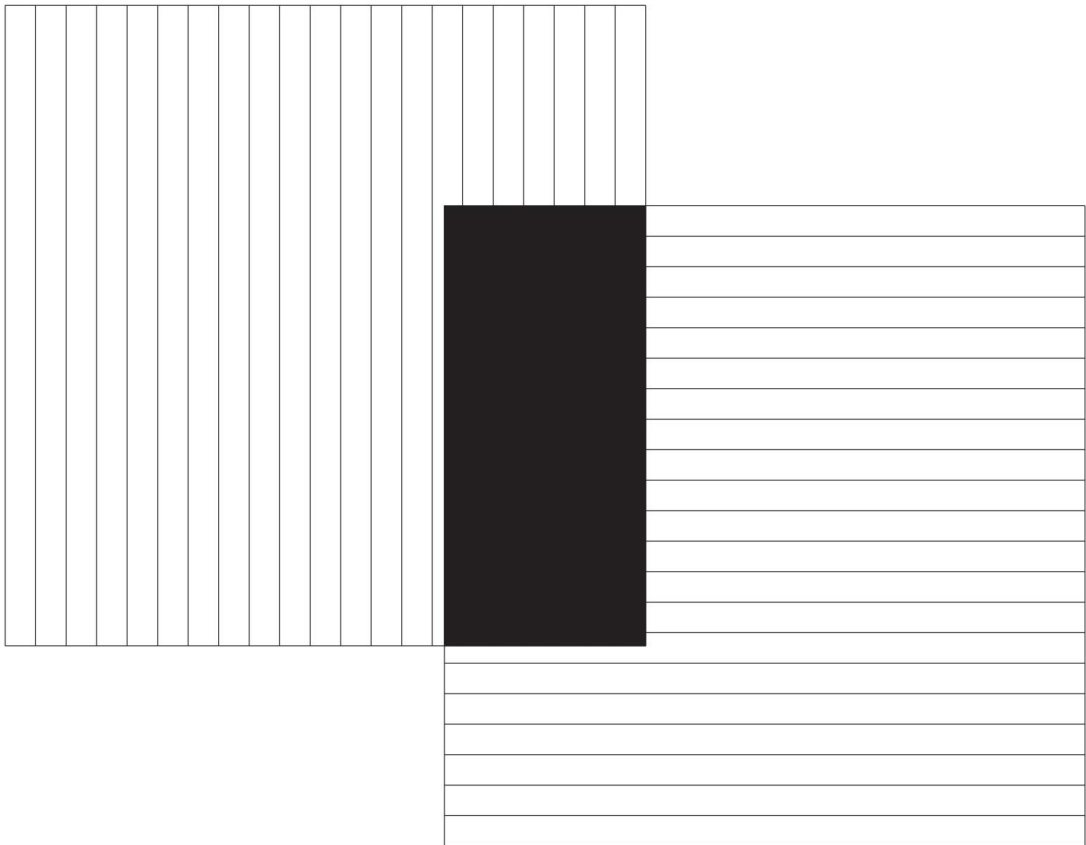

Materials:

- 2 polarizing filters, 2" x 2"
- 1 piece of mica (polarized muscovite)
- instructions



Explanation

What is happening?

When two polarizing filters are placed atop one another, they can be transparent or opaque to light. By rotating one of the filters, the transmitted light passing through the filters may be turned “on” or “off.” When the filters do not transmit light, the polarizing filters are said to be “crossed polarizers.” Certain materials such as cellophane tape, Plexiglas, corn syrup, and stretched polyethylene exhibit beautiful colors when placed between two crossed polarizing filters.

Experiments

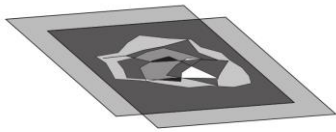

1. Place a piece of mica between two crossed polarizing filters. Each color represents a different thickness of the mica. Try rotating one polarizing filter. Try rotating the mica.

2. When a piece of Plexiglas is placed between two crossed polarizing filters and squeezed, stress lines appear. Engineers use this method to discover the stress areas in new structural designs.

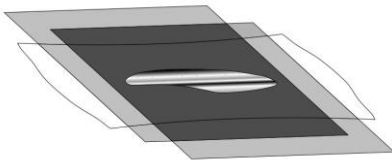
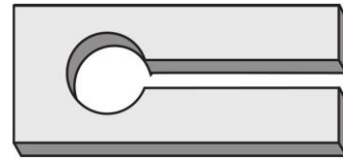

3. Place a piece of polyethylene between two crossed polarizing filters. Then stretch the polyethylene by pulling it. Examine the stretched polyethylene sheet between the filters.

4. Use the special cellophane tape to create designs on a sheet of acetate. Then examine the results by placing it between two crossed polarizing filters. Rotate one of the filters.

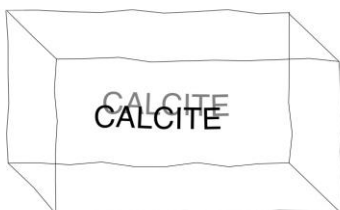
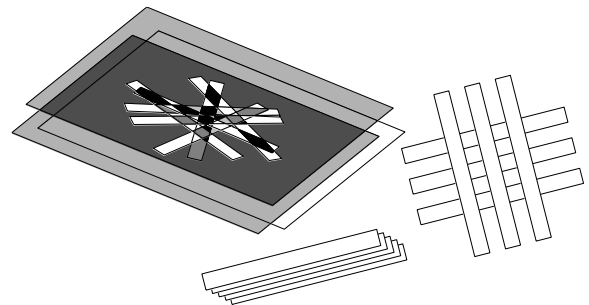

5. If you look at the words on a printed page through a crystal of calcite, you will see double. These natural, nearly transparent crystals exhibit the property of “birefringence,” i.e. they break light into two distinct polarized beams. By rotating a polarizing filter over the crystal, it is possible to view one image at a time. This phenomenon can be displayed using an overhead projector.

About Polarizers

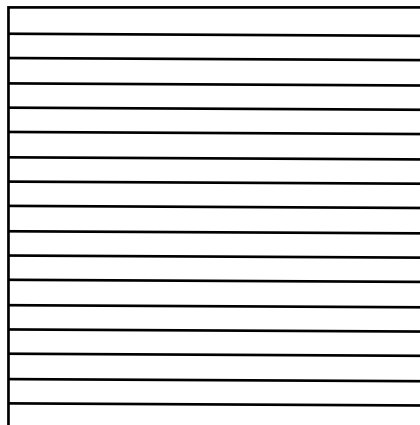
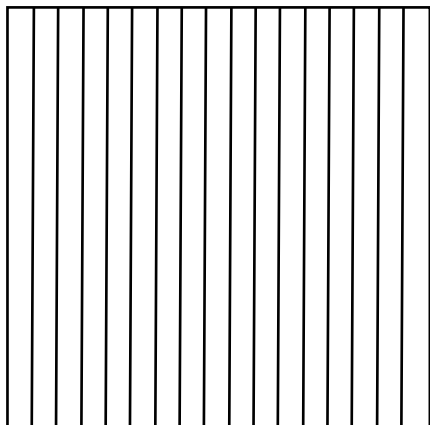

Only vertically oriented light waves may pass through the polarizing filter on the left. Only horizontally oriented light waves may pass through the filter on the right. If the filter on the left is placed on top of the filter on the right, no light will be able to pass through at all.

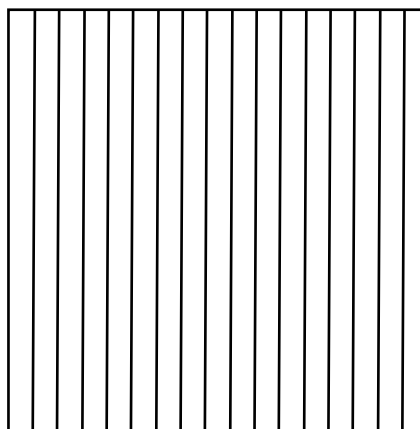
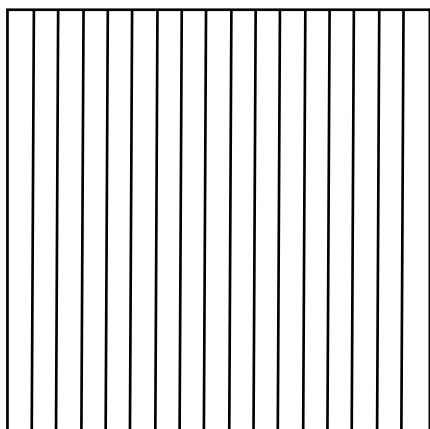

If the polarizing filters are aligned parallel to each other, light may pass freely through both filters. By placing transparent objects between two polarizing filters, it is possible to identify those materials which rotate polarized light!

Try sandwiching a plastic baggie between two filters and stretching it. When certain plastics are put under stress, they rotate polarized light.

Try placing transparent tape between two polarizing filters. Some brands of tape work better than others. The more layers of tape, the more the light is rotated.

NGSS Correlations

Our Polarizing Filter Demo Kit and these lesson ideas will support your students' understanding of these Next Generation Science Standards (NGSS):

Elementary

1-PS4-3

Students can use this tool to conduct an investigation of how different materials affect the path of a beam of light.

** NGSS is a registered trademark of Achieve. Neither Achieve nor the lead states and partners that developed the Next Generation Science Standards were involved in the production of, and do not endorse, this product.*

Middle School

MS-PS4-2

Students can use Polarizing Filters to develop and use a model to describe how waves are reflected, absorbed, or transmitted through various materials.

High School

HS-PS4-1

Students can use Polarizing Filters to conduct investigations and use mathematical representations to support a claim regarding relationships among the frequency, wavelength, and speed of waves traveling in various media.

HS-PS4-1

Students can use Polarizing Filters to experiment and model how light waves are altered when transmitted through various materials.

Suggested Science Idea(s)

MS-PS4-2

HS-PS4-1

Students can use Polarizing Filters to experiment and model how light waves are altered when transmitted through various materials.

Take Your Lesson Further

As science teachers ourselves, we know how much effort goes into preparing lessons. For us, “*Teachers Serving Teachers*” isn’t just a slogan—it’s our promise to you!

Please visit our website
for more lesson ideas:

[TeacherSource.com/lessons](http://www.TeacherSource.com/lessons)

Check our blog for classroom-tested
teaching plans on dozens of topics:

<http://blog.TeacherSource.com>

To extend your lesson, consider these Educational Innovations products:

Centripetal Spinner (PHY-250)

The prettiest demonstration of centripetal force and inertia we've ever seen! This perky, iridescent device reflects a dazzling rainbow as it spins. Twirl the stick and the thin ribbons spread into a bubble shape. The faster you spin, the wider the bubble becomes! It can be gently twisted by hand to make a delicate “flower” that neatly tucks itself into a tight ball. Endlessly fascinating!

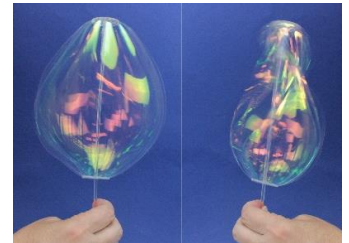

Polarizing Filters (PF-3A, PF-4, PF-5 and PF-12)

These high quality plastic polarizing filters are perfect for all kinds of experimentation. Can be cut with scissors or an ordinary paper cutter. Available in various sizes from 2.75" to 39."

Bismuth Crystal (RM-520)

These beautiful man-made crystals float to the top of a super-cooled bismuth melt and form within minutes. Bismuth is one of the few materials that have a greater density as a liquid than as a solid. Only a few other materials such as water, gallium, and germanium exhibit this property. The trigonal crystal structure accounts for the cubic formations. The iridescent rainbows of colors observed are caused by light scattering off thin layers of bismuth oxide formed when the surface of the hot bismuth reacts with the air. Specimens range from 12 to 17 g with a density of 9.81 g/cc. Great for teaching about crystals, states of matter, or even as a gift!



Prism Glasses (PG-1)

These highly efficient, double axis, holographic diffraction grating lenses separate light from any source into its spectral components for study and analysis. Lenses are mounted in sturdy cardboard frames. Sold in sets of 10.

